



M610053
10.06.2022

BANCHETTO DA LAVORO





ISTRUZIONI DI MONTAGGIO

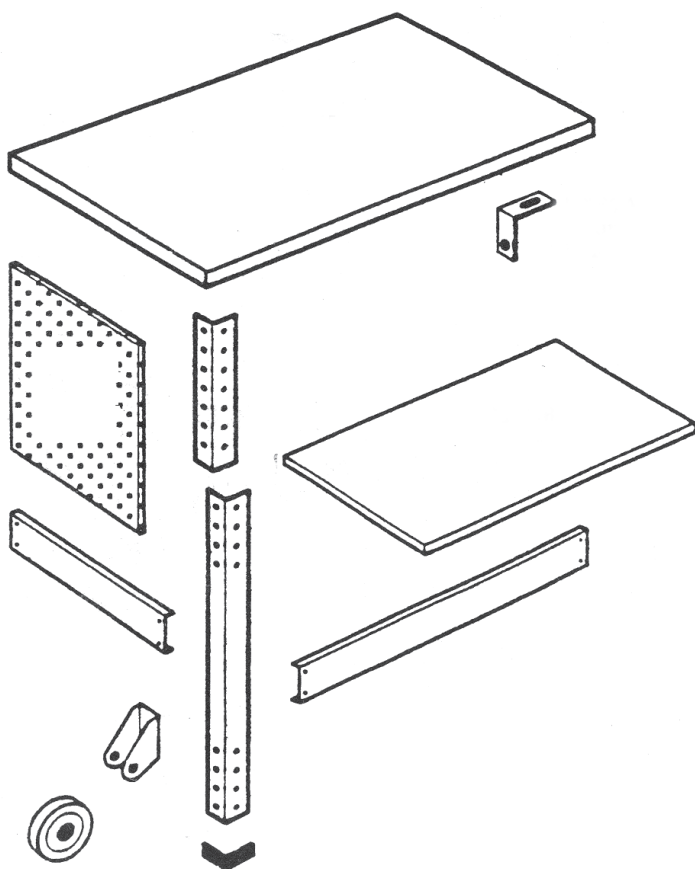

ATTENZIONE! Prima di usare l'attrezzatura, leggete attentamente le istruzioni per l'uso.

Componenti per il corretto montaggio del banco da lavoro



-  M6 - 8 pezzi
-  M5 - 44 pezzi
-  TE M5x12 - 52 pezzi
-  2 pezzi
-  4 pezzi

A

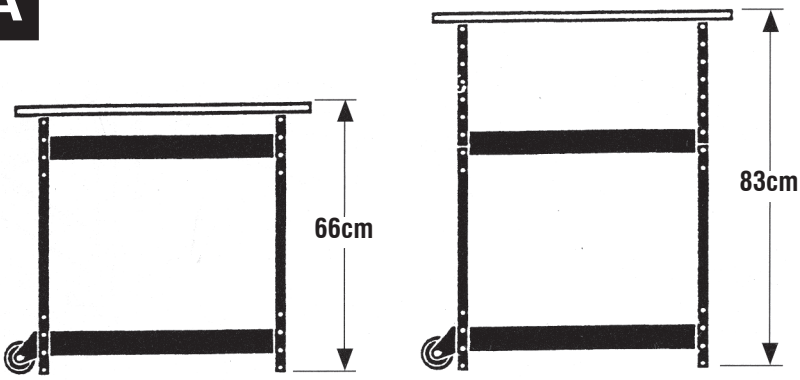

Altezza variabile del piano di lavoro

Il banco presenta la possibilità di differenti regolazioni del piano di lavoro; per variarne l'altezza svitare le viti di fissaggio delle barre di supporto e spostarle verso l'alto fino al foro corrispondente all'altezza desiderata. Fissare in maniera salda le viti al fine di evitare movimenti del piano durante il proprio lavoro

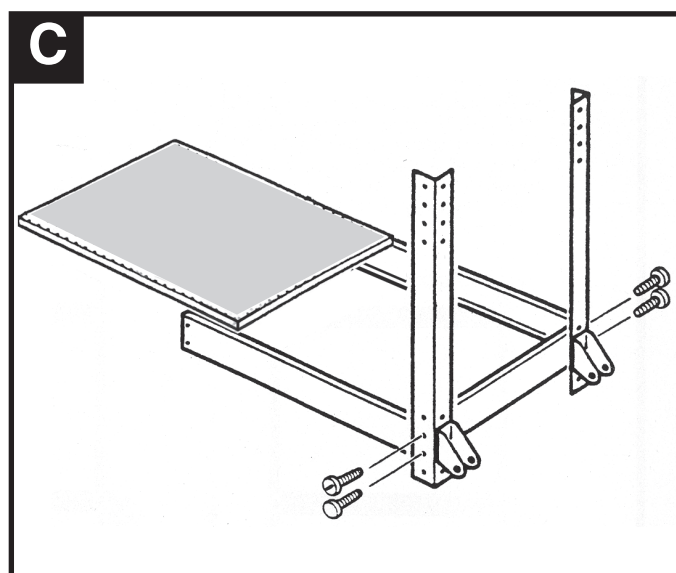
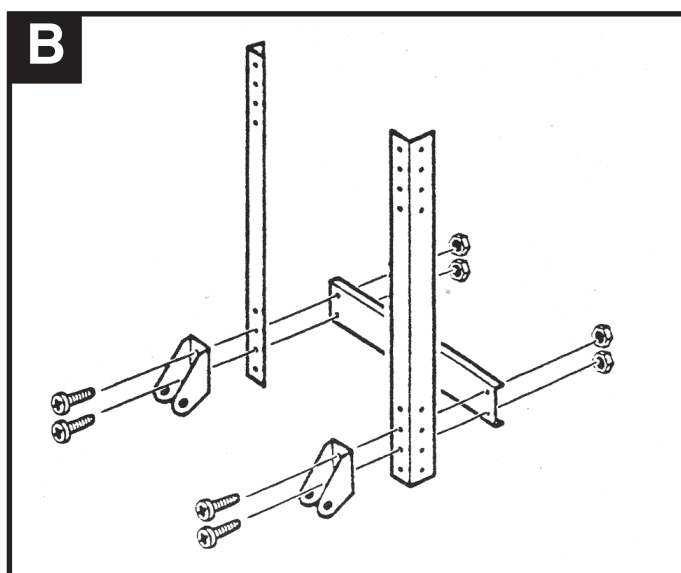

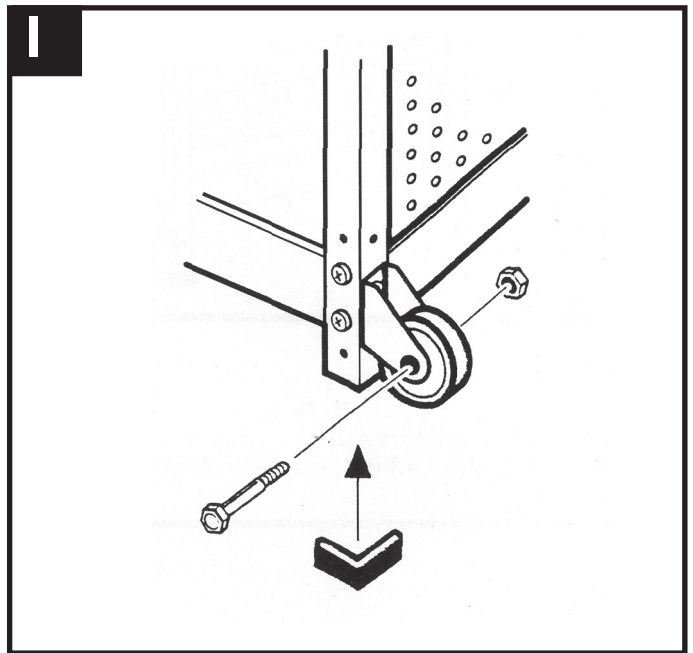
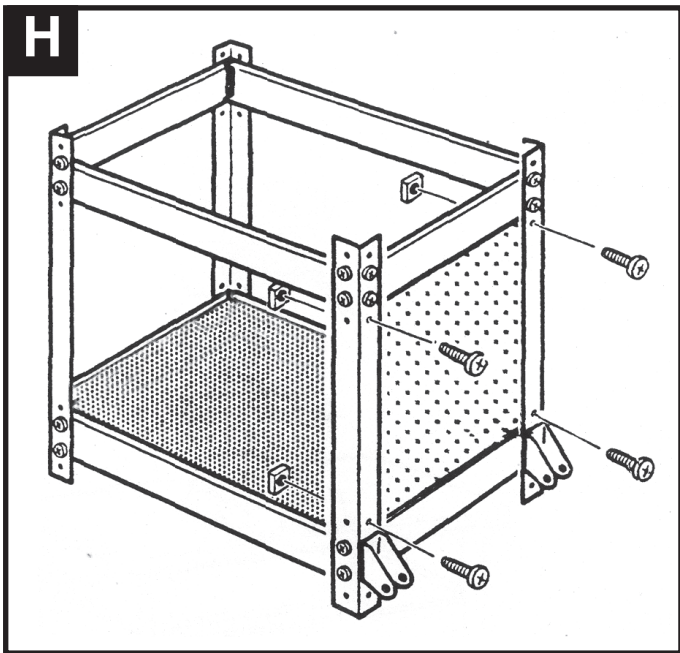
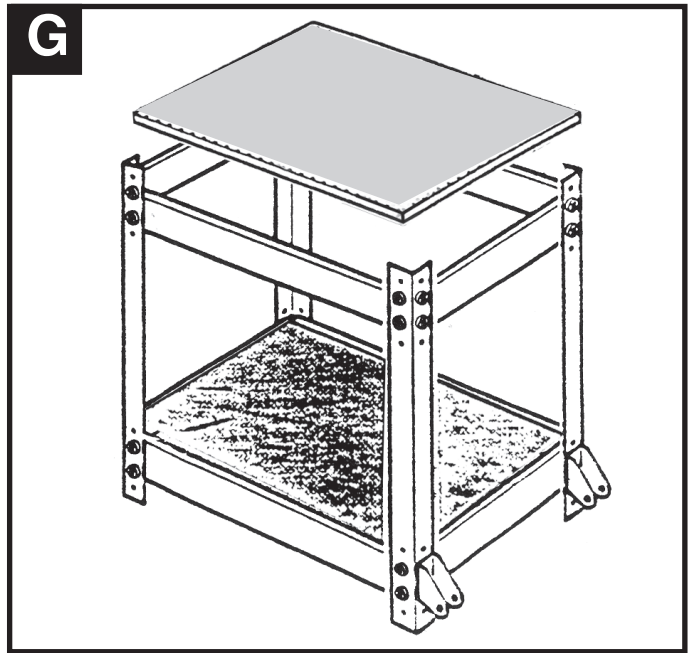
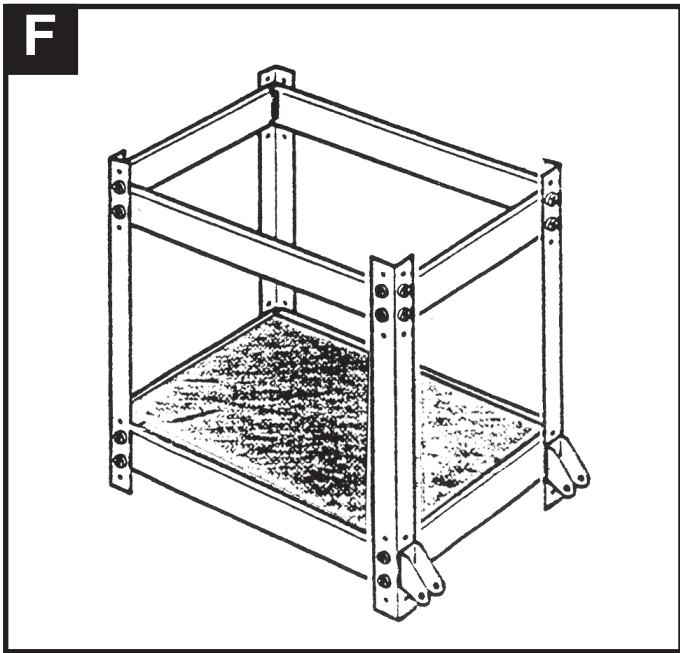
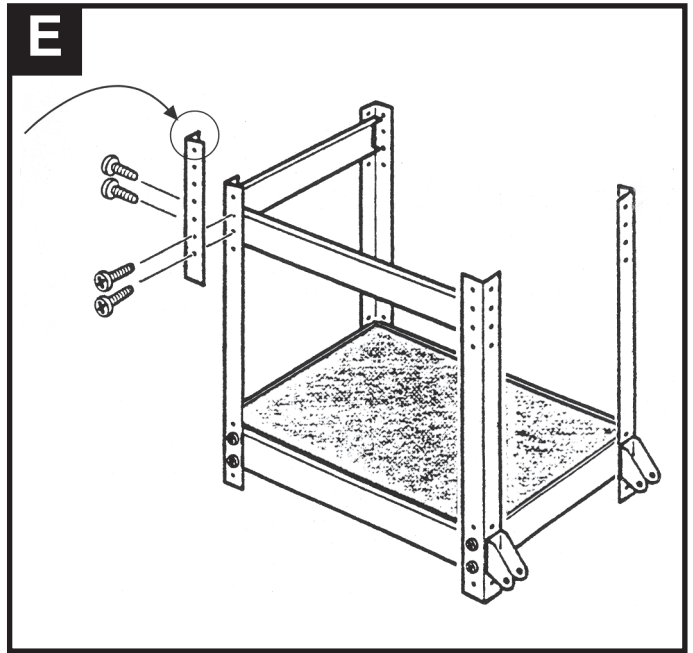
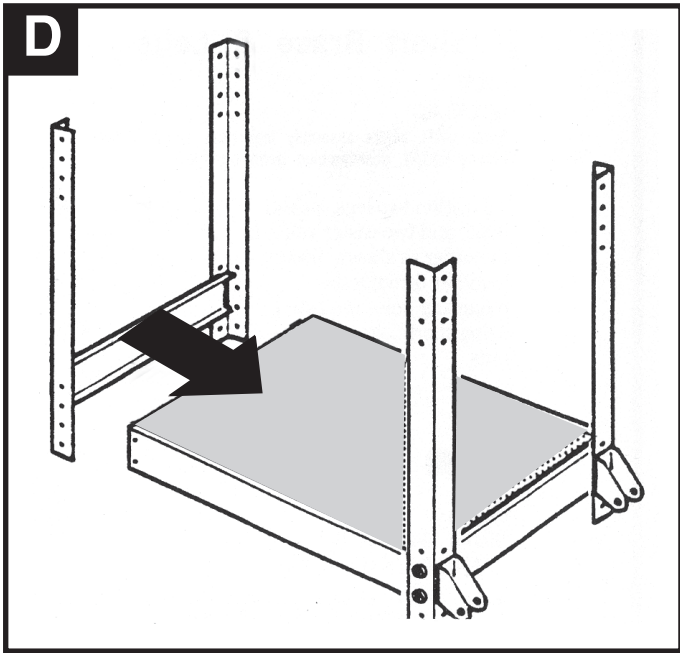

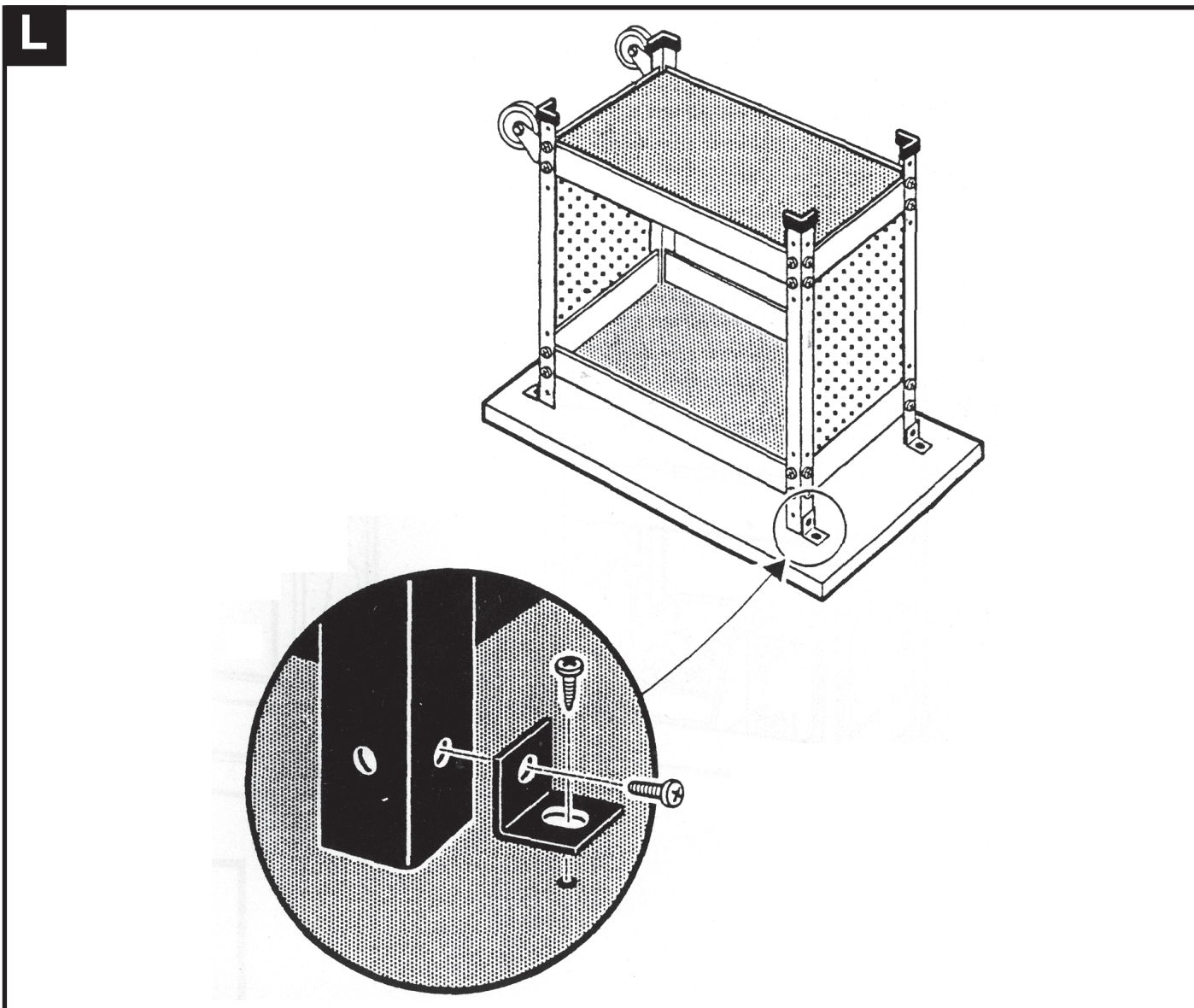

ATTENZIONE! Revisionate periodicamente il corretto serraggio di tutte le viti. Viti fissate in maniera approssimativa possono causare movimenti inaspettati del piano di appoggio durante il lavoro.